

DO NOT RETURN THIS PRODUCT TO RETAILER

Return Merchandise Authorization Number (RMA#) is Required. To obtain RMA #, Technical Support or to review Troubleshooting Videos and Step-By-Step Troubleshooting Procedures please visit www.AquaProducts.com/Service.

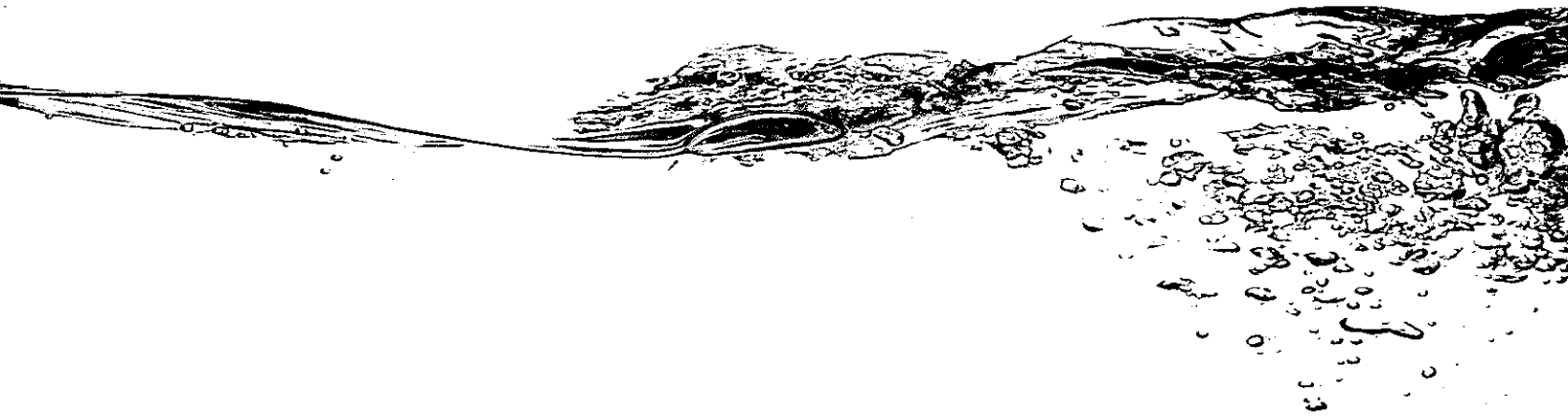

**JET TECHNOLOGY
OPERATOR MANUAL
AND
TROUBLESHOOTING GUIDE**

Please Read Carefully Before Using Your Pool Cleaner

This manual is for use with a variety of Aqua Products Robotic pool cleaners.

AQUA PRODUCTS

THE WORLD'S LEADER IN ROBOTIC POOL CLEANING SOLUTIONS



TABLE OF CONTENTS

Table of Contents.....	2
Welcome.....	2
How it Works.....	3 - 4
Operating Instructions.....	5 - 6
Power Supply & Floating Cable Connection	7
Quick Setup Instructions	8
Setting the Forwards / Reverse Timer	9
Knowing / Using Model Features	9-10
When to Clean the Filter Bag / Removing Cleaner from pool / Cleaning or Changing the Filter Bag	10
Troubleshooting.....	11-12
Cleaner Storage	12
Preparing Your Cleaner for Shipping.....	13-14

WELCOME

Dear Customer,

Welcome to the family of Aqua Products and congratulations on purchasing the most reliable pool cleaner technology on the market today! Your new cleaner is a fully automatic, "robotic" mobile filtration system engineered with the patented SimplyReliable™ hydraulic jet drive propulsion system. Working without any of the complex circuitry or wearable drive components found on all other cleaner types your cleaner eliminates the hassle of hoses, the expense of costly to run booster pumps and works independent of external pump and filtration systems to save you money and time. To get the most out of your investment, be sure to read this operator manual as you will find within it tips on how to keep your robot running smoothly to continue to save you money for years to come. Feel welcome to visit our site at AquaProducts.com for the latest product information, including additional savings tips, troubleshooting videos and more.

This manual is for use with a variety of Aqua Products Robotic pool cleaners.

www.AquaProducts.com/Service

HOW IT WORKS

Rather than connecting to your pool's filter or requiring a booster pump, your cleaner is equipped with its own built-in Pump Motor that provides it the ability to vacuum dirt and debris independently. An internal, reusable Filter traps the debris allowing only clean water to pass through. The filtered water that is expelled is efficiently used to hydraulically drive or "jettison" your cleaner about the pool.

Saving Your Wallet & The Planet

Mobile Filtration System

Your cleaner vacuums and traps fine dirt and large debris internally, reducing the work load from your pool's filtration system. In essence, your cleaner is a mobile filtration system that works without hoses or costly, energy consuming main pool pumps or booster pumps. Your pool's main filtration system will therefore require less cleaning and operating time. Less main filter system cleaning (if backwashing is needed to clean it) to the tune of thousands of gallons of water saved annually, and save you up to 80% of filter media replacement (be it cartridge, D.E., sand or equivalent), plus extend the life of your pool's filter and pump.

Eco-Efficient

Every hour that your cleaner works to keep your pool clean is an hour that you may run your pool's filtration system less by up to 70% in total, which can save you as much as \$2,000 a year in energy. Your cleaner's pump redistributes chemicals suspended in the lower, cooler, chemically rich waters within your pool to mix with the warmer, chemically depleted water above. By doing so it provides a more uniform chemical composition yielding a healthier swimming environment and a more accurate water test sample. That plus a cleaner pool means less chemicals needed - by as much as 30% less. The same powerful mixing action can raise temperatures in lower waters by several degrees, saving you even more money and energy by reducing heater usage. This mixing also saves you even more water by decreasing the temperature above resulting in reduced evaporation. And by reducing main filter backwashing / cleanings you save both thousands of gallons of water annually and as much as 80% of filter media replacement, while greatly reducing the negative impact chemically treated water has by entering the environment. It feels good to save money and really great when you're also doing your part for our environment!

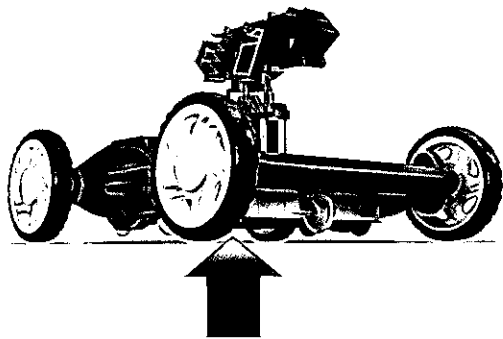

1. The Pump Motor sucks in water, dirt and debris.

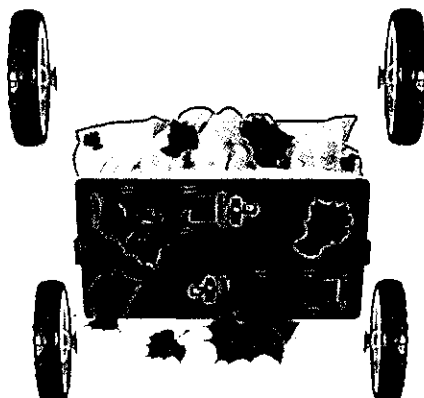

2. Large leaves, dirt and debris are separated by offset Debris Intake Ports (to avoid clogging) and are then trapped within the internal, reusable Filter Bag.

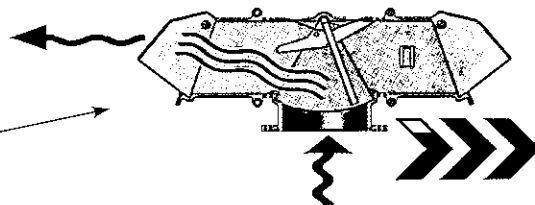

3. The micro-filtered water travels upwards to the Directional Valve Flap which forces the water out either front or rear Jet Propulsion Valve Port. The forced water provides thrust to hydraulically jet propel your cleaner to roll about your pool as it circulates the water.

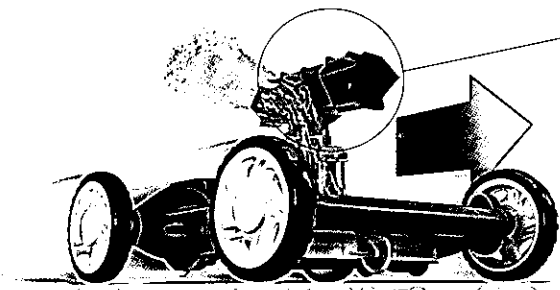

Complete Coverage

Like a car, your cleaner has two Axles; the front Axle turns your cleaner and the back axle is fixed. Your cleaner will operate using one of two turning systems; Locking Pin or Mechanical Wedge.

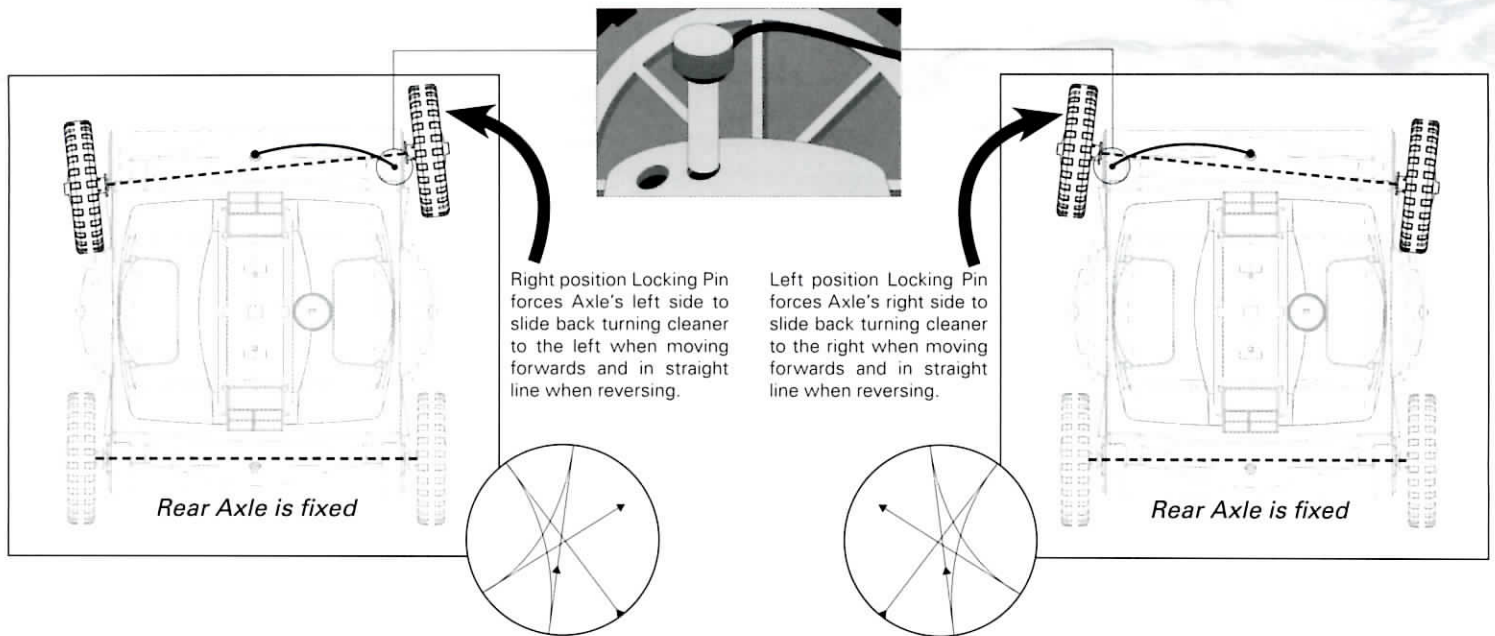

Locking Pin: The front Axle can slide all the way forwards and backwards in its slot. By simply inserting the provided Locking Pin into a either the left or right Locking Pin Holes so that the Front Axle is in front of the Locking Pin away from the cleaner's body. This way, one side of the front Axle will remain forwards at all times, while the other side will freely slide back and forth depending on the direction your cleaner is traveling. When your cleaner moves forward, the free side will slide towards your cleaner's Body, while the locked side will remain in place causing your cleaner to turn in a curved motion. When your cleaner reverses, the free side will slide back to a parallel position with your cleaner's Body and rear fixed Axle, creating a straight line movement. The result is a systematic, highly efficient scanning pattern. Know that the Floating Cable will turn in a circular pattern each cleaning cycle and it is therefore important to alternate the Locking Pin position to the Locking Pin Hole on the other side of the Axle to reverse the turning circular pattern with each use.



IMPORTANT: At the begining of EVERY cleaning cycle it is very important to move the Locking Pin from its current Locking Pin Hole to the same Hole position on the opposite side of the Axle! Failure to alternate the Locking Pin as specified will result in the Floating Cable twisting and may require costly repairs!

Mechanical Wedge: Hidden within the front Axle Guard there is a Mechanical Wedge that forces your cleaner's front Axle to turn either to the left or to the right every time your cleaner moves forwards or backwards. This enables your cleaner to move organically with the natural contours of your pool rather than work against it as other cleaners do with their gear systems and drive motors. The result of the natural movements is full freeform coverage of any pool shape.

*Mechanical Wedge Turning System models may also be equipped with a Locking Pin to allow you to override your cleaner's natural turning tendencies to either restrict the degree of turn or provide for a systematic turn depending on where the Locking Pin is inserted." If sliding the Axle forwards so that the Locking Pin is between the Axle and your cleaner's body, you will create a systematic turn as described under Locking Pin above on this page. This is the ideal setting for narrow pools, like lap pools or for systematic floor-only cleaning of most rectangular pools. If you slide the Axle back towards the cleaner's body and place the Locking Pin in so that it restricts the degree that the Axle can slide, you will reduce the turning amount of your cleaner. This is more suited for large, wider pools. Read and follow the IMPORTANT message above regarding usage of the Locking Pin.

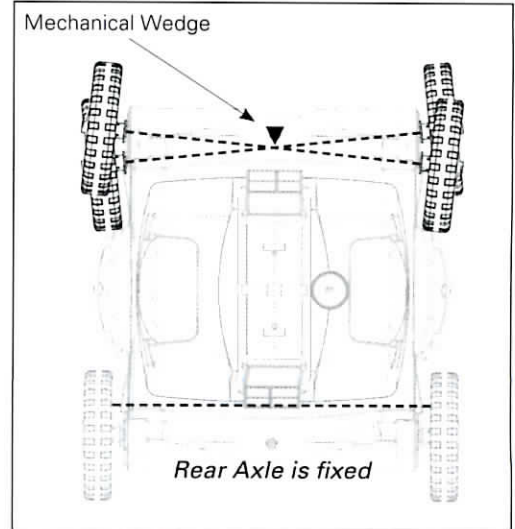

OPERATING FEATURES

This manual has been created to represent the set-up and troubleshooting practices required for a variety of Aqua Products cleaners. Although the shape and color of some components featured herein may not be identical to those of your cleaner, their operating and service procedures are. As there are a variety of features and components applicable to the various models produced, some pages may show features not available on your cleaner model. Please disregard these while fully reviewing the material applicable to your specific cleaner model.

Figure 1
What's inside?

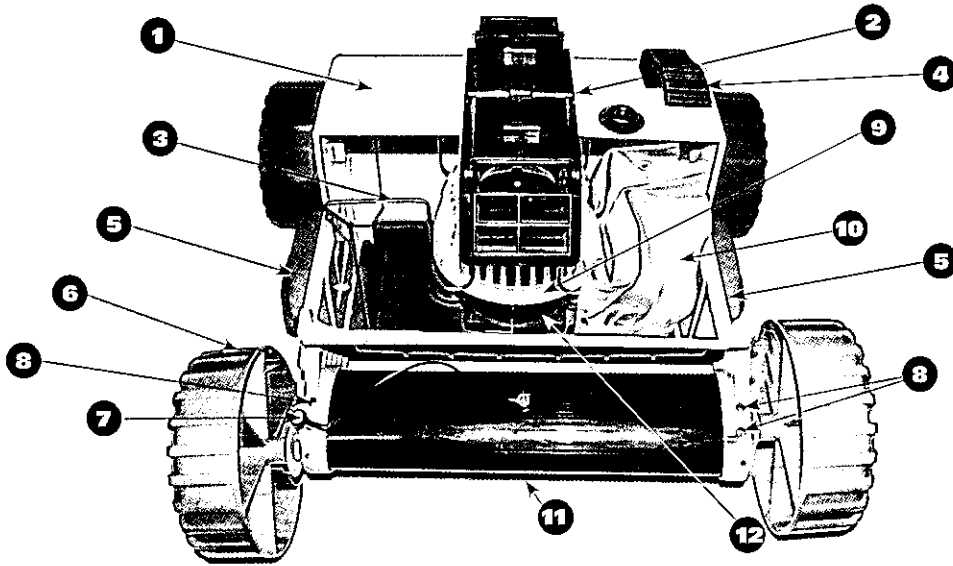

- | | |
|----------------------------------|----------------------------|
| 1. Cleaner Body | 7. Locking Pin |
| 2. Jet Propulsion Valve Housing | 8. Locking Pin Hole(s) |
| 3. Filter Bag Wire Support Frame | 9. Protective Motor Screen |
| 4. Top Handle | 10. Filter Bag |
| 5. Side Plate "Handle" | 11. Front Axle Guard |
| 6. Wheel(s) | 12. Pump Motor |

Figure 2
Cross-section of Pump Motor and Jet Valve Housing

- | |
|--|
| 12. Pump Motor |
| 13. Jet Propulsion Valve Port(s) |
| 14. Directional Valve Flap |
| 15. Propeller |
| 16. Propeller Housing |
| 17. Hydro-Scrubbing / Power Washing Tube(s)* |

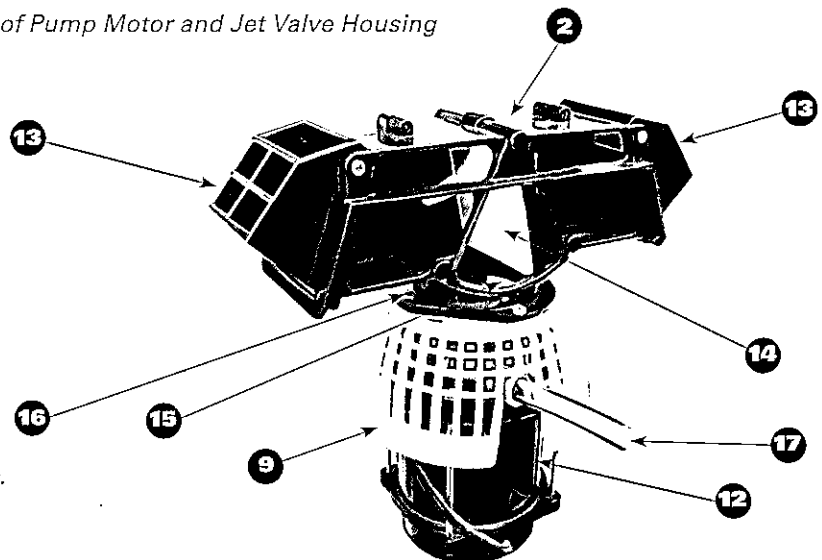

* Note: Hydro-scrubbing Jets are NOT available on all models.

01 RATING FEATURES

Figure 3a

BOTTOM LID ASSEMBLY

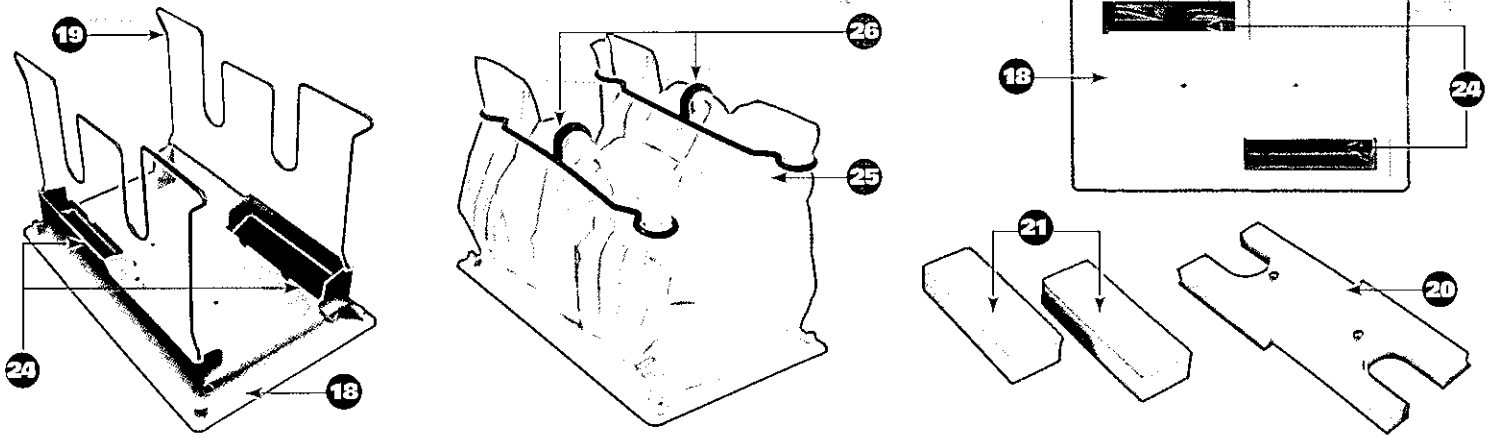
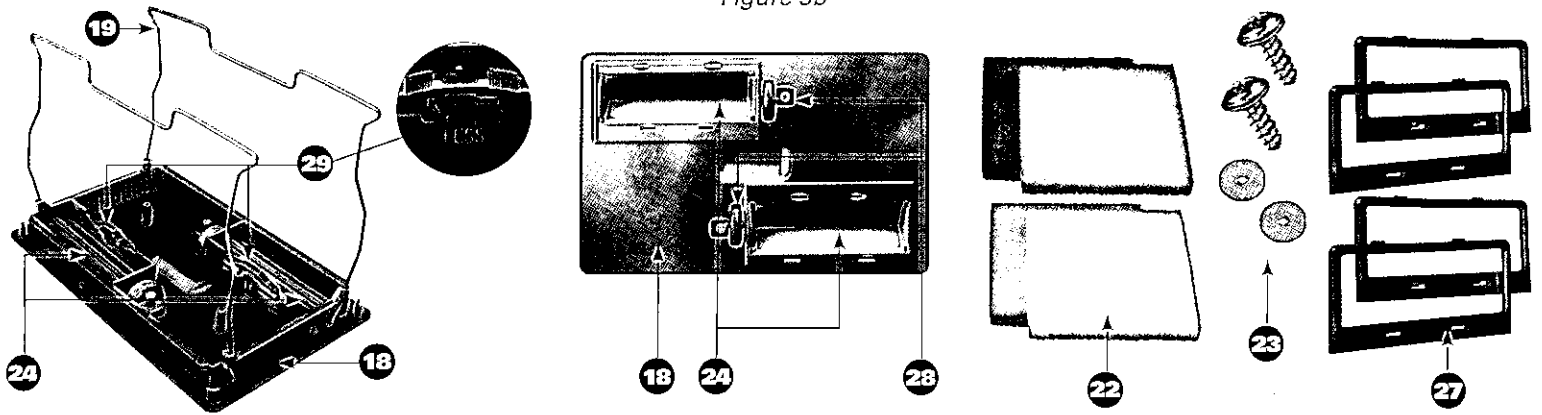

Figure 3b



- 18. Bottom Lid
- 19. Wire Frame Bag Support
- 20 "H"-Float
- 21. Side Pocket Floats

- 22. Square Floats
- 23. Float Screws & Washers
- 24. Debris Intake Port / Flaps
- 25. Filter Bag

- 26. Filter Bag Clips
- 27. Variable Port Depth Extensions
- 28. NeverStuck™ Rollers
- 29. Debris Intake Port Width Selector

Power Supply & Floating Cable Connections

Fig. 4

Power Supply (Transformer) with:

- Built-in Forwards/Reverse Timer
- Built-In 2-Hour Automatic Shut-Off

1. Power Supply
2. Power (ON/OFF) Switch
3. Socket (For Floating Cable)
4. Fuse Holder
5. Power Supply Cord
6. Extended Time Button
(See NOTE below)

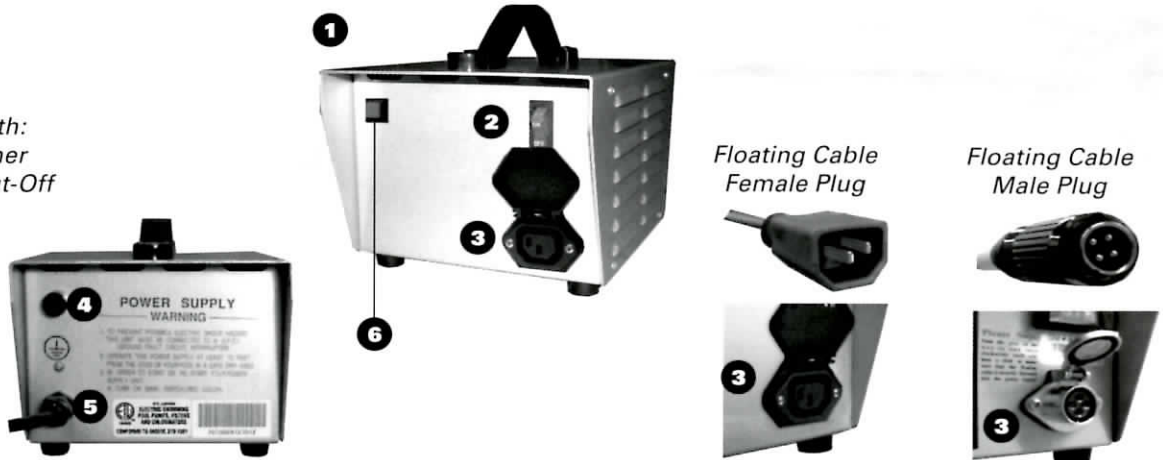

NOTE: New Special Power Supply with Extended Time Capability: Start the cleaning cycle by pressing the Main Power ON / OFF Switch to the ON position. The Cleaner will start to travel back and forth along the pool. For pools where its most narrow point is more than 24' in length, and use of Power Supply as is results in areas of the pool not being cleaned - press the Power Supply's red Extended Time Button. Once pressed this Button will illuminate indicating that its forward / reverse timed movements have been extended to accommodate the larger pool size.

Fig. 5

Power Supply (Transformer) with:

- Adjustable 0-90 Seconds Digital Timer
- Built-In 2-Hour Automatic Shut-Off and External Timer Operable

1. Power Supply
2. Power (ON/OFF) Switch
3. Socket (For Floating Cable)
4. Fuse Holder
5. Power Supply Cord
6. Continuous Run
7. Safety Reset Button
8. Up/Down Time Buttons
9. LED Time Display

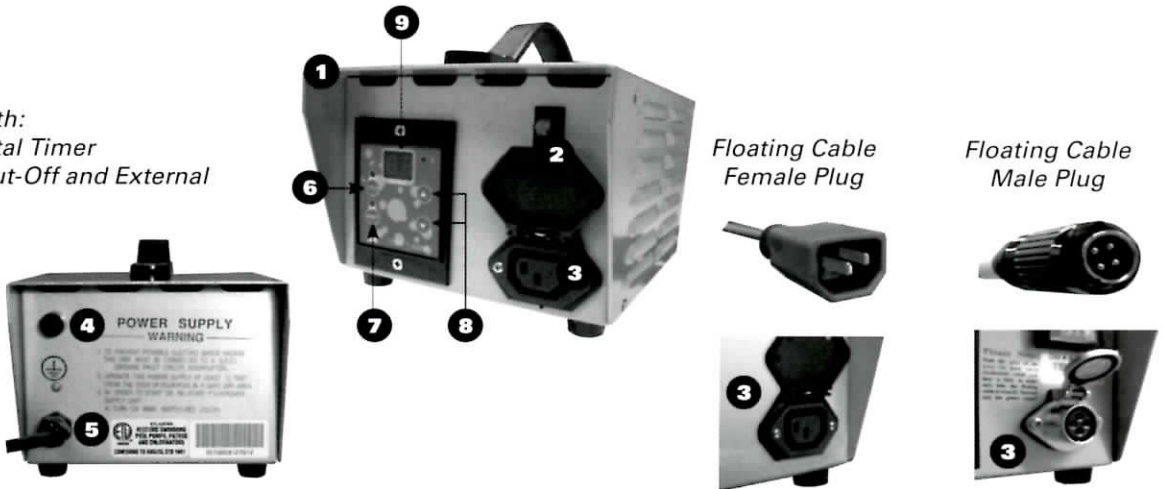

CAUTION: Due to the risk of electric shock or death, do NOT open or tamper with Power Supply! There are NO user-serviceable parts inside! Refer servicing to Authorized Service Center or Manufacturer only!



CAUTION: Always unplug the Floating Cable from the Power Supply when your cleaner is out of the water to prevent any possible out of water operation, which will result in costly damage and repairs!

QUICK SETUP INSTRUCTIONS



Never allow anyone to swim in the pool while the cleaner is in the pool!

STEP 1

LOCATION, LOCATION, LOCATION OF YOUR POWER SUPPLY

1. They say location is one of the most important factors, and in the case of your Power Supply, they are right. Place the Power Supply in a dry, sheltered area at least 12 feet / 4 meters away from the pool. Since the Power Supply is water resistant, not water proof, it should be placed in an elevated dry area where it will be sheltered from water and rain.
2. Plug the Power Supply Cord into a standard Ground Fault Circuit Interrupter (GFCI) / Residual Current Device (R.C.D.) protected outlet. If a protected outlet is not close enough, then a proper outdoor grounded extension cord may be used to connect to the nearest grounded outlet as indicated above. Remember to always keep the Power Supply at least 12 feet / 4 meters away from the pool.



WARNING! The Power Supply should be placed in a sheltered area, at least 12 feet / 4 meters away from the pool! While the Power Supply is weather-resistant, it is not water-proof and therefore should be placed in an elevated, sheltered area where it will not sit in water or rain!



TIP! For optimum cleaning performance locate the Power Supply at the mid-point of your pool's longest side. This will allow your cleaner to make the best use of its Floating Cable length without using excess Cable, which could result in it unnecessarily twisting or kinking. Excess Cable should be kept coiled outside the pool near the Power Supply.

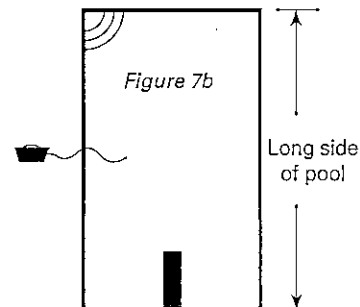
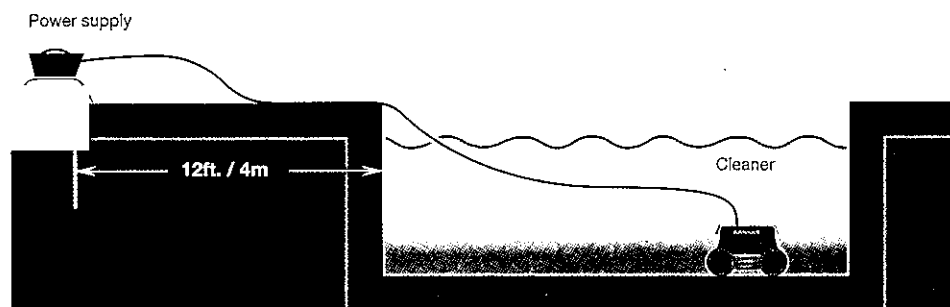

WARNING! The Power Supply may only be connected to a Ground Fault Circuit Interrupter (GFCI) / Residual Current Device (R.C.D) to protect your electric outlet and to prevent from possible electrical shock!



CAUTION! Never operate your cleaner when it is not totally submersed in the pool water! Doing so may cause severe damage to motor and require costly repairs!

STEP 2

PLACING YOUR CLEANER IN THE POOL

1. With the Power Supply ON/OFF Switch in the OFF position, plug the Floating Cable into the Power Supply Socket.
2. If your cleaner does NOT have a Mechanical Wedge Turning System and / or requires the Locking Pin (see page 4), insert the Locking Pin at this time.
3. Holding your cleaner firmly by its Handle (never by its Axle or Floating Cable) with a finger pressed on the Locking Pin (if Locking Pin is needed), place your cleaner in the pool upside down, gently tilting it side to side to allow any trapped air to escape. While still submersed, with the air removed, turn your cleaner right side up and allow your cleaner to sink to the pool bottom, with its Wheels down.

NOTE: If your cleaner does not sink it is because air is still trapped inside. Repeat Step 2.

4. If your pool is elongated (rectangular, oval, etc.), insert your cleaner at the middle of the pool's length and uncoil the Floating Cable that extends from the cleaner's body and spread it evenly over the pool water surface allowing adequate Cable length to reach the entire pool. Excess Cable in pool may result in unnecessary coiling or tangling.



CAUTION! Always hold and remove your cleaner from the pool by its Handle only - never by its Axle or Floating Cable. Doing so will result in unnecessary costly repairs.



WARNING! Set the operating mode for your cleaner after the cleaner has been placed in the pool, the Floating Cable from the cleaner has been plugged in to the Power Supply and the Power Supply has been plugged into a GFCI / R.C.D. protected 115v grounded electrical outlet!

SETTING THE FORWARDS / REVERSE TIMER

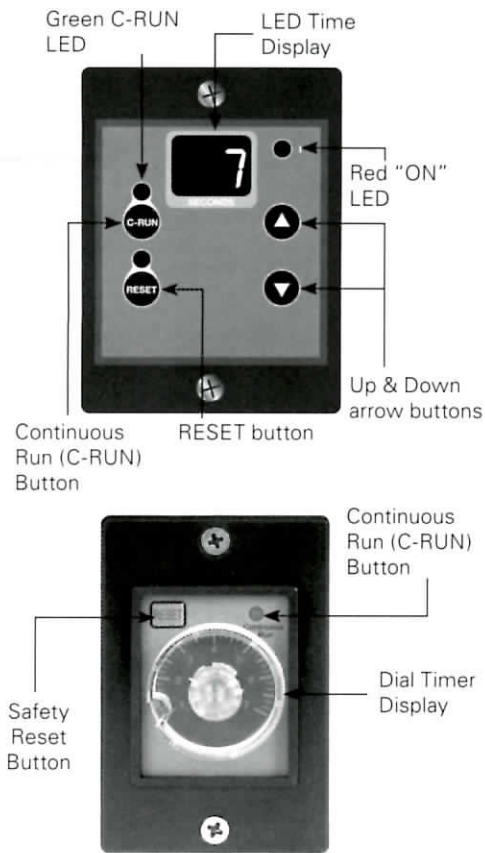

If your cleaner's Power Supply features an adjustable Timer (Dial or Digital), you can control the length of the forwards / reverse movement time of your cleaner by using the control pad on the Power Supply.

TIMED OPERATION: SET IT AND FORGET IT

The optimal amount of time to set your cleaner's movements for is the amount of time it takes your cleaner to move from the furthest point of one side of the pool, where it can no longer move forwards, to the closest point where it can no longer reverse, and rest there for several seconds before reversing. Once you have set the it, you can forget it, from here on you can forget it as your Power Supply will recall this set time each time you turn it ON.

Digital Timers: Press the Up facing Arrow Button once for each additional second of movement you desire (up to 90 seconds) or the Down facing Button for less seconds (down to one second).

Dial Timers: Rotate the Dial Timer clockwise to increase the amount of time your cleaner will move (up to 60 or 90 seconds depending on your model) and counterclockwise to reduce the number of seconds.

NOTE: As your cleaner's internal Filter becomes saturated with dirt both large and invisible to the naked eye the amount of flow coming through it will reduced reducing its jet propulsion flow and your cleaner will move more slowly taking longer time to cross the pool. By the end of its cleaning cycle it may only spend about one second each time it reaches the furthest point.

NOTE: You may add or subtract seconds while your cleaner is operating and this new time will be set and recalled with each subsequent use.



WARNING! Set the operating mode for your cleaner after the cleaner has been placed in the pool, the Floating Cable from the cleaner has been plugged in to the Power Supply and the Power Supply has been plugged into a GFCI/R.C.D. protected electrical outlet.



WARNING! The Power Supply should be placed in a sheltered area, at least 12 feet / 4 meters away from the pool. While the Power Supply is weather-resistant, it is not waterproof and therefore it should be placed in an elevated, sheltered area where it will not sit in rain or puddles of water!



IMPORTANT: In "External Timer" mode, the Safety Reset button feature becomes inactive and can not protect your cleaner.

KNOWING / USING MODEL FEATURES

This Continuous Run (C-RUN) feature is only applicable to models with Digital Timers.

Continuous Run Operation (C-RUN)

Continuous Run mode means that your cleaner will operate continuously until you physically press the ON / OFF Switch to OFF. After pressing OFF, to restart its operation again, you must physically press the Power Supply Power Switch back to ON.

Digital Timers

1. Turn the Main Power ON / OFF Switch to "ON".
2. Press the "C-Run" (Continuous Run) button until it is lit. Your cleaner is now set to Continuous Run mode.



WARNING! In "Continuous Run" mode, the Safety Reset button feature becomes inactive and can not protect your cleaner from accidental "out of water" start up! Therefore, it is imperative that you always unplug the Floating Cable from its Power Supply when removing your cleaner from the pool!



WARNING! Set the operating mode for your cleaner after the cleaner has been placed in the pool, the Floating Cable from the cleaner has been plugged in to the Power Supply and the Power Supply has been plugged into a GFCI/R.C.D. protected electrical outlet!

OPERATING INSTRUCTIONS

WHEN TO CLEAN FILTER BAG

It is suggested that you clean the Filter Bag after every use to ensure the strongest hydraulic drive and vacuum suction. When your cleaner begins to slow down considerably by constantly reversing direction before reaching portions of the pool it would normally reach, it is sending you a signal that it is time to clean the Filter Bag. Always thoroughly clean the Filter Bag and rinse your cleaner and its components prior to storing it for any length of time.



IMPORTANT: Although a Filter Bag may appear clean it is capable of microfiltering out particulates 20 times smaller than what the naked eye can see! It is crucial to thoroughly clean the Bag with each use to ensure its ability to properly cover and clean your pool!

REMOVING CLEANER FROM THE POOL

1. When your cleaner has completed its cleaning cycle (either internal 2-Hour or based on the adjustable time set if your cleaner model has this feature) it will automatically shut off. Turn off the Power Supply by pressing the ON/OFF switch to the OFF position.
2. With your cleaner in the pool, gently pull it toward you using the Floating Cable. When your cleaner is within reach, reach and grab its Handle firmly and remove it from the water using the Handle only - NEVER BY THE FLOATING CABLE! Rest your cleaner on its back / top to allow water to drain from its body.



TIP! When resting your cleaner on its side, be sure to place it on a non-abrasive surface (i.e. Towel, doormat, etc.) to avoid scuffing and scratching your cleaner.



IMPORTANT: Using the Floating Cable or Axle to hold your cleaner will cause severe damage to your cleaner's Floating Cable and may result in costly repair!



IMPORTANT: Do not remove cleaner from pool for 20 minutes after cleaning cycle is complete to allow its motor(s) to adequately cool and avoid costly motor damage!

CLEANING OR CHANGING THE FILTER BAG

NOTE: Make sure that the Power Supply is turned OFF and that your cleaner's Floating Cable is unplugged from the Power Supply before removing your cleaner from the pool.

1. With your cleaner on its back on a soft surface, to avoid scratching it, use your thumbs to push the Lock Tabs (located on the sides of your cleaner's underside) away from the center of the cleaner to unlock the Bottom Lid Assembly to release the Bottom Lid Assembly that holds the Filter Bag.
2. Remove the Bottom Lid Assembly out from the Body of your cleaner.
3. Remove Filter Bag Clips from each Wire Frame.
4. Remove the Filter Bag from the bag support Wire Frames.
5. Turn the Filter Bag inside out (the Fine Filter Bag has a soft felt-like surface on the inside), discard the large debris, and wash off visible dirt using a high pressure garden hose or by dunking it in a clean bucket of water while gently agitating the Bag in your hands to help remove fine particles, and ringing the Bag until rinse water becomes clear. You may machine wash (Gentle Cycle / Cold Water ONLY) the Bag with NO DETERGENT OR BLEACH. DO NOT iron or machine dry the Filter Bag.
6. Turn the Filter Bag "right side out" (felt-like surface on the inside), remount the Bag on the Wire Frames making sure that the Label on the Bag is centered on either of the long sides of the Bottom Lid Assembly directly beneath one of the Wire Frames.
7. At the top, pull excess Bag toward the middle of each Wire Frame so that the Bag corners are snug against the corners of the Wire Frame and bunch the excess Bag into the center area of the Wire Frames.
8. Reinstall each Filter Bag Clip to hold the Filter Bag in place on each Wire Frame.
9. Reinstall the Bottom Lid Assembly. Make sure that neither debris nor the Filter Bag itself interferes with complete closure of the Bottom Lid Assembly. A locking sound from each Lock Tab will be heard when locked properly.

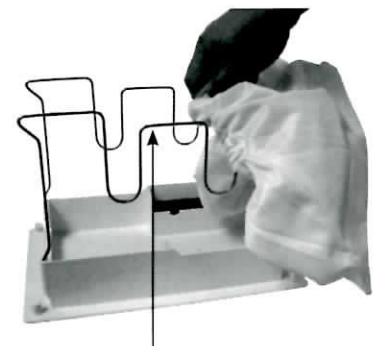

Wire Frame Bag Support

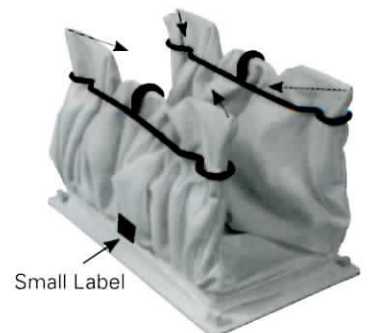

Small Label

TROUBLESHOOTING

Should none of the troubleshooting procedures provided herein correct your specific issue, please visit our customer service department online at AquaProducts.com/Service to view troubleshooting videos and step-by-step procedures or contact our Customer Service department via email at CustomerService@AquaProducts.com or by phone toll free at 1-800-845-4856.

Moves slowly or inefficient vacuuming

- Check to see if the Filter Bag is thoroughly clean. Refer to CLEANING OR CHANGING THE FILTER BAG in this manual for further instructions on best cleaning methods.

NOTE: Use the Fine Filter Bag to trap smaller debris such as algae, bacteria, sand and silt. Use the Mesh Filter Bag to trap larger debris such as leaves, acorns, twigs and pine needles. It may be necessary to rinse with high pressure water and wring the Filter Bag in a bucket of clean water.

- To verify whether the Filter Bag is still dirty despite looking clean remove the Bag, reinstall the Bottom Lid (without the Bag), and operate your cleaner in the pool without the Bag. If your cleaner moves quickly, but now does vacuum dirt as it should, this is an indication that your Bag is not clean enough, and you must repeat the cleaning instructions until the Bag is thoroughly clean.
- Check to see if the Intake Valve Flaps on the bottom of your Cleaner/Bottom Lid Assembly freely open and close to allow the entry of water and debris.



IMPORTANT: The Fine Filter Bag is capable of filtering particles 20 times smaller than the naked eye can see. Therefore, thorough cleaning of the bag may be required!

Does not cover the entire pool

- Adjust the timing cycle on the Power Supply so that your cleaner reaches the other side of the pool until it can no longer move forwards and remains there for several seconds before reversing direction.
- Check to see if the Filter Bag is clean and not clogged with debris, especially fine dirt. Refer to TROUBLESHOOTING: Moves slowly or inefficient vacuuming above for detailed instructions on additional troubleshooting check points.
- Check to see if the Wheel rotation and Axle movement is free of obstructions like hair, string or accumulated debris and the Axles are not worn, which would then require replacement.
- Check to see if the Floating Cable has adequate length to reach all sides of the pool and is not tangled or hooked as this will limit the movement of your cleaner.
- Your cleaner's Side Plate features impressions along side the existing Locking Pin Holes. If you have tried the other Troubleshooting procedures with no resolution, you may force the Locking Pin into the Locking Pin Hole impressions using a gentle tapping of the Locking Pin with a hammer. This will allow you to modify the degree of arcing turn that your cleaner makes when moving in the forward position to help it to cover the pool.

Does not reverse direction

- With your cleaner's Floating Cable unplugged from the Power Supply, unscrew the two Screws that hold each of the Jet Propulsion Valve Ports onto the Jet Propulsion Valve and remove both Ports.
- Unscrew by about a 1/2 turn the two Screws on both sides of the top of the Jet Propulsion Valve and use your finger to try and spread apart the Valve so that it is separated only fractionally.
- Take a high pressure garden hose and spray into the Jet Propulsion Valve Housing at each Jet Propulsion Valve Port. This should free any particulate that may be impeding the movement of the Directional Valve Flap.
- With your screwdriver gently push straight back against the Directional Valve Flap and pull back to see if the Valve changes direction and follows your press each time. If not, the internal Spring that helps your Directional Valve Flap change direction may require replacement. Please visit AquaProducts.com/Service to locate an Authorized Service Center to have this inspected, and if necessary, replace with a new Spring.

Cleaning the Propeller

- With your cleaner's Floating Cable unplugged from the Power Supply, unscrew the two Screws that hold one of the Jet Propulsion Valve Propulsion Ports onto the Jet Propulsion Valve and remove the Port.
- Bend a common "giant" paper clip into a hook and push the center Directional Guidance Flap in the Valve Housing with a screwdriver to open it and look at the Propeller for debris like hair, string or other object like a small twig that might be caught in or around the Propeller obstructing it from freely rotating. Use the paper clip and try to hook and pull out the debris to free the Propeller.

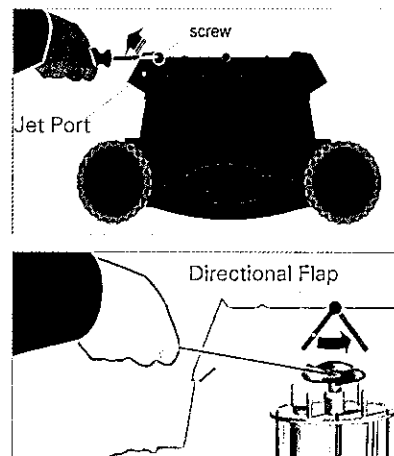

IMPORTANT: Make sure your cleaner is turned OFF, unplugged the cleaner from the Power Supply and the Power Supply from the outlet to avoid any accidents or injury when cleaning the Propeller and/or the Jet Propulsion Valve Ports.



CAUTION: To reduce the risk of electric shock or death, do not remove electrical components, Motor or Power Supply screws or rivets! No user-serviceable parts inside! Refer servicing to Authorized Service Center or Manufacturer only!

TROUBLESHOOTING

Reverses before reaching the opposite end of the pool

- Turn the Time Control Dial (located on the Power Supply) clockwise a few degrees or adjust the Digital Timer using the "up" Button to increase the time between reversals. Repeat if necessary.
- Check to see if the Filter Bag is thoroughly clean and installed properly. Know that the Filter Bag is capable of trapping particulates down to 20 times smaller than what is visible to the naked eye. To verify whether what appears to be a clean Filter Bag is actually dirty, remove the Filter Bag and operate your cleaner with the Bottom Lid Assembly installed. If your cleaner now performs as it should - then the Filter Bag requires a more thorough cleaning and agitation to remove embedded dirt that is restricting its vacuum ability and flow rate for movement.

Waits too long at the side of the pool before reversing

- Turn the Time Control Dial on the Power Supply counter-clockwise a few degrees or adjust your Digital Timer using the down arrow Button to decrease the forwards / reverse time. Repeat if necessary.

Floating Cable is twisting

- Your new pool cleaner was designed to clean most pools without issue, but since every pool is unique some pool shapes and / or the pool's filter system circulating water may cause the Floating Cable to coil or tangle. For this reason we offer the EZ-Swivel™ available at Authorized Dealers or at AquaProducts.com to help you to untwist your Cable more easily. To unravel the Cable using the EZ-Swivel™, disconnect the Power Supply Cord from the Power Supply, place your cleaner on the ground outside of the pool perpendicular to you. Secure your cleaner so that it will not move when you pull on the Floating Cable / EZ-Swivel Handle firmly and walk away from the cleaner while pulling the Handle. This will cause the Cable to rotate within the EZ-Swivel™ and force the Cable to untwist itself. For best results remember to pull the Handle until the Cable is fully twisted.

CLEANER STORAGE

When not in use it is important that your cleaner, its Floating Cable and Power Supply are properly stored in a clean and dry area, away from direct sunlight, protected from below freezing temperatures and exposure to chemicals and their fumes (i.e. chlorine). This will help prevent any unnecessary wear or damage to your cleaner or its components. Prior to storing your cleaner, thoroughly clean your Filter Bag and dry off your cleaner. Ensure that its Floating Cable is untangled, not twisted nor in a figure eight, but rather coiled either around your cleaner's body or in large circular loops and positioned under your cleaner away from potentially freezing temperatures and chemicals and their fumes (i.e. chlorine).

In-Season Storage

It is not recommended to leave your cleaner in the pool when not in use. Doing so, will reduce the life of your Filter Bag and pool cleaner. After removing the cleaner from the pool you should clean the Filter Bag and rinse down your entire cleaner to help extend its life and reduce fading. Then, rest the cleaner in a dry, shaded area along with its Power Supply and properly coiled Floating Cable.

Off-Season Storage

In geographic areas where the pool will be closed you should remove your cleaner from the pool and thoroughly clean the Filter Bag. Make sure that there is no water residue in the cleaner (freezing temperatures will freeze water - ice expands and could damage motor seals). Completely untangle and then properly coil the Floating Cable. Your cleaner and Power Supply should be stored in a dry, protected area away from potentially freezing temperatures and chemicals and their fumes (i.e. chlorine).



IMPORTANT: A Return Authorization Number (RMA) must be obtained from Aqua Products prior to shipping cleaner to its repair facility. Any item shipped to Aqua Products without a proper RMA number will be refused and returned!

PREPARING YOUR CLEANER FOR SHIPPING

In the event that you should have to send your cleaner in for repair, you must package the cleaner properly to ensure it reaches the repair facility safely and without incurring damage during transport. This will delay your repair turnaround time and require you to contact your shipper directly to dispute damages.

If the troubleshooting methods shown within the Troubleshooting Guide have not corrected your technical service issue or has proven that your cleaner requires review by an Aqua Products Authorized Service Center, please visit Aqua Products' Customer Service Department online at AquaProducts.com/Service to locate your local Authorized Service Center.

NOTE: A log of all information from your contact with an Aqua Products technical service analyst (i.e. RMA, name of analyst, dates, cleaner model and serial number, etc.) should be kept with your operator manual and / or other important documents for your reference.

- 1 Ask the technical service analyst whether the Power Supply needs to accompany the cleaner. If yes, the Power Cord should be coiled (Fig. 5a) and the Power Supply should be entirely well wrapped in bubble-wrap or equivalent protective material (Fig. 5b). The Power Supply should be positioned in the center of the base of the shipping box and the shipping box base must be firmly sealed (Fig. 5b).

Figure 5a

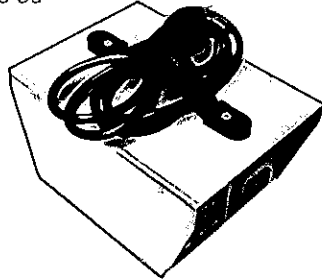
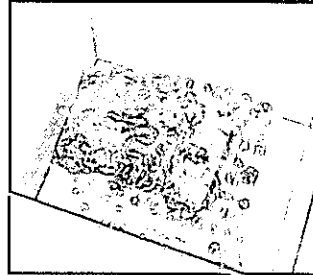

Figure 5b



- 2 The cleaner's Floating Cable should be coiled and encircled around the Power Supply located at the base of the shipping box (Fig. 6).

Figure 6



- 3 A protective barrier (preferably thick cardboard) should be placed on top of the Floating Cable and Power Supply (Fig. 6a).

Figure 6a



- 4 Your cleaner should be completely wrapped in bubble-wrap or equivalent protective material. The protected cleaner should be positioned in the center at the base of the protective barrier that is shielding the cleaner from the Power Supply and the Floating Cable underneath. Insulated protective material like bubble-wrap should be placed between the cleaner and the shipping box at walls and top to secure the cleaner and around shipping during transit (Fig. 6b).

Figure 6b



5

Include a copy of all information obtained during your contact with the technical service analyst and / or Authorized Service Center, including your contact information and cleaner's serial number in an envelope (Fig. 6c). A copy of the information relevant to the current technical issue should be sent in the packaging with your cleaner in an envelope. Please include a letter indicating the following:

- Technical issue
- Troubleshooting procedures that you completed
- Who you spoke with, when and what was determined (*Aqua Products and, if applicable, the Authorized Service Center*)
- RMA # if being sent to Aqua Products
- Your contact information (*name, email, phone number, address cleaner model name and serial number*)

Figure 6c

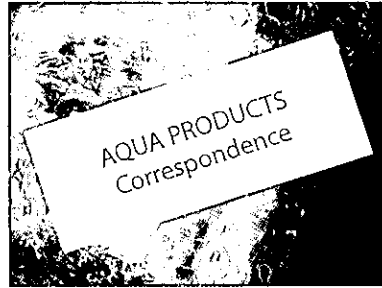
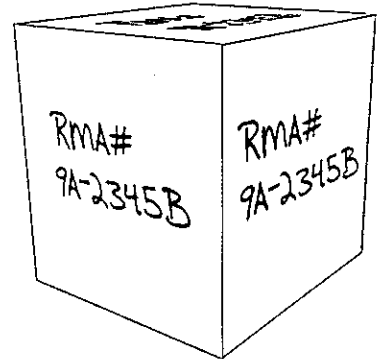

Figure 6d



IMPORTANT: Prominently list the RMA number on all six sides of the shipping box (preferably with magic marker). See Fig. 6d.



IMPORTANT: Keep a copy of your shipping information for tracking purposes!

MAKE A RECORD FOR FUTURE USE

MODEL _____
 PURCHASE DATE _____
 PLACE PURCHASED _____
 SERIAL NUMBER _____

NOTE: Serial number can be found on the warranty card, the packing carton and your cleaner.

QUESTIONS?

Contact the Retailer you purchased your cleaner from or visit the Manufacturer online at www.AquaProducts.com

LIVE TECHNICAL SUPPORT (NORTH AMERICA)

1-800-845-4856

June - August

9:00am - 8:00pm (Mon. - Fri.)

9:00am - 1:00pm (Sat.)

September - April

9:00am - 5:00pm (Mon. - Fri.)

(All Times are Eastern Standard Time Zone)

ONLINE TECHNICAL SUPPORT AND PRODUCT INFORMATION

www.AquaProducts.com/Service

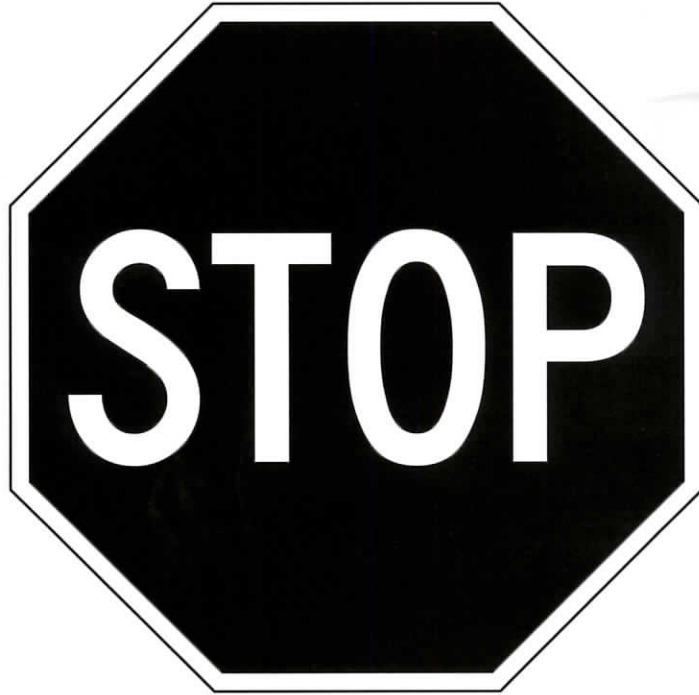

DO NOT RETURN CLEANER TO RETAILER!

If you have a technical service issue
**PLEASE REFER TO THIS MANUAL OR
CONTACT AQUA PRODUCTS DIRECTLY FOR
IMMEDIATE SUPPORT**

Note that the absolute majority of technical issues can be resolved over the phone (1-800-845-4856), by referring to this Operator manual or reviewing troubleshooting videos and information online anytime at www.AquaProducts.com/Service.